

Clarius®

Clarius® LT Small

The Clarius® LT range of entry level Infra-Red LED illuminators are designed to provide class leading performance, long life and ultra low maintenance.

Incorporating the latest Dual Core surface mount LEDs with enhanced optical output and outstanding reliability, they deliver excellent night-time images.

Each unit is fitted with integrated control circuitry to carefully control LED output, delivering consistent illumination and projected working life in excess of 10 years.

Installation is quick and easy, requiring only a 12-32V DC +/- 10%.

PRODUCT FEATURES

- Small IR Illuminator
- Latest SMT Dual Core LED™ Technology
- Distances Up To 20m
- 850nm Wavelength
- Low Power Consumption (12W)
- Long Life
- 3 Year Warranty
- IP67 Weather Proof Rating
- Integrated Photocell
- 12-32V DC +/- 10%
- CleanLITE® Self Cleaning Lens Coating Technology
- Easy Installation

RECOMMENDED PSU

Model: ALT-30-24
Output: 24 VDC / 1.25A Max
Input: 100-250 V AC / 0.45A
 50/60Hz
Ratings: IP67
Dimensions: 200 x 20 x 29mm



SECTORS



RESIDENTIAL



COMMERCIAL



INDUSTRIAL



BORDERS



MILITARY BASES



PORTS



POWER PLANTS



HERITAGE



AIRPORTS



PRISONS

MODEL NUMBER	WAVELENGTH	ANGLE	DISTANCE		FOV	
IS-830-LT	850nm	30°	20m	66'	11m	36'
IS-890-LT	850nm	90°	15m	49'	30m	98'

Other angles available on request.

TECHNICAL SPECIFICATIONS

GENERAL

Electronics

High Efficiency Surface Mount **Dual Core** Power LED's With Advanced Current Limited Integral Control Circuitry

Construction Front Window

Robust High Quality Aluminium Extrusion Polycarbonate High Transmission Vandal Proof IR Filter with **CleanLITE®** Technology

Finish

Black Anodised

Power Cable

3m (9ft)

Photocell

Preset 50 Lux

Operating Temperature

-50° to 50°C (-58° to 122°F)

Weight

750g (1.6lbs)

Mount

Powder Coated Stainless Steel Wall Mount

Dimensions

68 x 110 x 54mm (2.68" x 4.33" x 3.07")

ELECTRICAL

Input Voltage

12-32V DC +/- 10%

Input Current

0.5A at 24V DC

Consumption

12W

WAVELENGTH

Standard

850nm (Semi Covert). Faint Red Glow Only

CERTIFICATION

Safety

EN60598:2004

Electrical Safety

EN60825-1

Laser Eye Safety

IP

IP67 In Accordance With EN60529:1992

EMC

EN61000, FCC Part 15. 107

15. 108 Class B

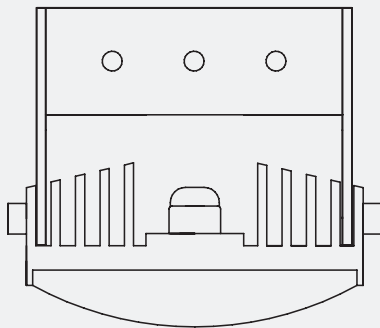
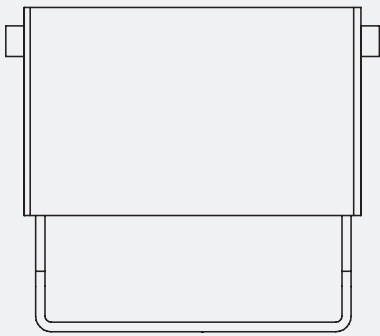
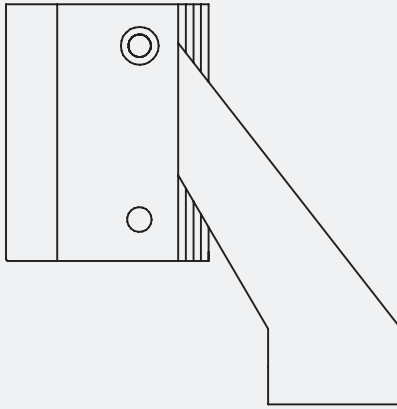

RECOMMENDED PSU



Model:

ALT-30-24

Output:

24 VDC / 1.25A Max

Input:

100-250 V AC / 0.45A

50/60Hz

Ratings:

IP67

Dimensions:

200 x 20 x 29mm

Please note GJD reserve the right to change the information within this document, without notice. **DSISLT-31-08-15**

www.gjd.co.uk | info@gjd.co.uk | +44 (0) 1706 363 998

Unit 2 Birch Business Park, Whittle Lane, Greater Manchester, Lancashire, OL10 2SX

